



ROBINSON R44 II CC-PCS



COTIZACIÓN ROBINSON R44 RAVEN II S/N 10713

Matricula: CC-PCS

Año de Fabricación: 2005

T.T. Actual Helicóptero: 804.5 Horas

T.S.N. Actual Motor: 804.5 Horas

En atención a la solicitud de cotización para el helicóptero marca Robinson, modelo R44 II, matrícula CC-PCS, tenemos el agrado de cotizar conforme al siguiente detalle:

I. Dimensiones y Especificaciones Técnicas

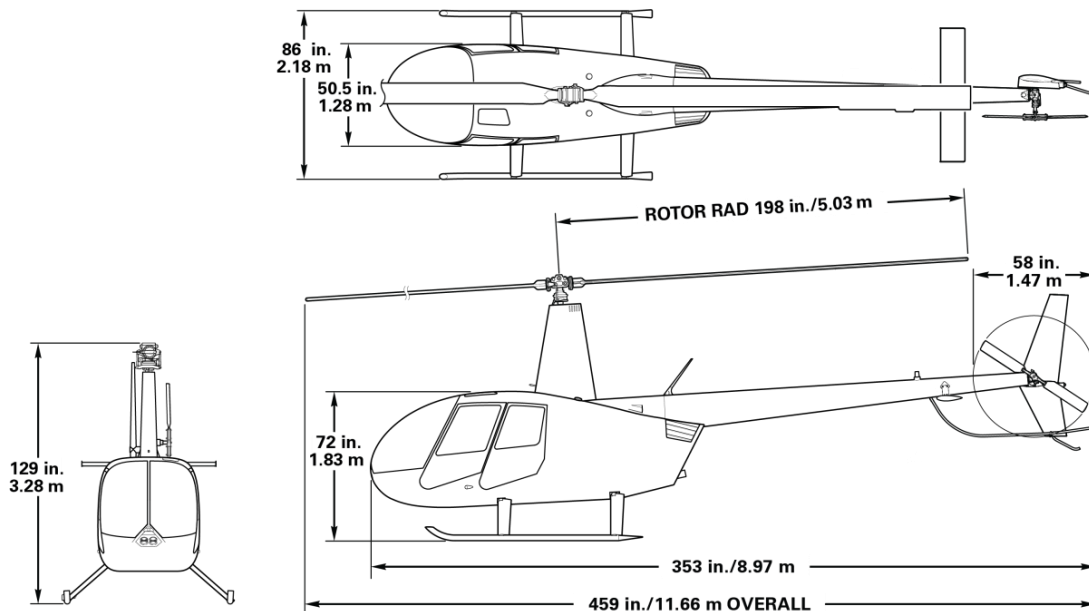

Especificaciones Técnicas Robinson Raven II

• Engine	Lycoming IO-540, six cylinder, fuel injected
• Horsepower	Derated to 245 for takeoff and 205 continuous
• Maximum Gross Weight	2500 lb (1134 kg)
• Approximate Empty Weight (including oil & standard avionics)	1505 lb (683 kg)
• Standard Fuel (29.5 gal)	177 lb (80 kg)
• Auxiliary Fuel (17.0 gal)	102 lb (46 kg)
• Pilot, Passengers, and Baggage (with standard fuel)	818 lb (371 kg)
• Cruise Speed at Maximum Gross Weight	up to 109 kts (202 km/h)
• Maximum Range (no reserve)	approx 300 nm (550 km)
• Hover Ceiling IGE	8950 ft @ 2500 lb
• Hover Ceiling OGE	7500 ft @ 2300 lb
• Rate of Climb	over 1000 fpm
• Maximum Operating Altitude	14,000 ft
• Electrical System	28 volt

II. Configuración del Helicóptero



Configuración del Helicóptero	
Configuración	Corporativo
Tripulación/ Pasajeros	1 Piloto/ 3 Pasajeros
Equipos Instalados	
Vertical Card Compass	
King VHF Transceiver	
King Transponder	
Blind Encoder	
Nat Audio Control (Single)	
Artex ELT	
Garmin GPS	
Avionics Cooling Blower	
Altimeter (in Hg)	
Vertical Speed	
Astrotech Chronometer	
Turn Coordinator	
Comant COM Antenna (Aft)	
King Transponder Antenna (-3)	
Artex ELT Antenna	
Comant COM/GPS Antenna (Fwd)	
Strut Fairings	
7 Instrument Console	
Bubble Windows Doors (Fwd)	
Bubble Windows Door (Aft)	
Alternator (24V)	
Oil Filter	
Rem. Cyclic Grip	
Rem. Collective Stick	
Rem. Pedals	
Fire Ext Pocket Only (Fwd)	
04 Bose A10	
Hydraulic System	
Shield - Muffler, Tailpipe	
Battery- Underseat	
Battery Relay	
Sistema Estático	
Sistema Pitot	
Indicador de Velocidad	
Ind. Deslizamnto./ Derrape	
Indicador O.A.T.	
Horómetro	
Amperimetro	
Indicador Tacómetro Dual	
Indicador P. Carga	
Indicador Presión Aceite	
Indicador Temp. Aceite	
Ind. Temp. Cabeza Cilind.	
Indicador Cant. Combust.	

III. Precio y Forma de Pago

El precio del helicóptero es de US \$360,000.00 + IVA.

Forma de Pago: Posterior a la ejecución y firma de la LOI, el oferente/comprador tiene 05 día hábiles para realizar el depósito correspondiente a un 4% del valor de compra de la aeronave en la cuenta de Eagle Copters S.A., a título de reserva y constituirá un anticipo del precio de venta acordado, en caso de efectuarse la compraventa.

La diferencia entre el precio de compra pactado y el depósito de reserva, impuestos aplicables incluidos, será pagadero, salvo que se pacte algo diferente, mediante depósito a plazo en USD endosable, el que quedará en notaría con instrucciones de entregarlo al vendedor una vez que la aeronave haya quedado debidamente inscrita a nombre del oferente/comprador en el respectivo registro del conservador de aeronaves de la DGAC.

IV. Plazo de Entrega

Una vez ejecutados y firmados los respectivos acuerdos, contratos e inscripciones a nombre del nuevo propietario de la aeronave, esta será entregada de forma **inmediata**.



V. Fotos



VI. Anexos

Plan de Reemplazo Componentes Aeronave

AGROTORES
TRABAJOS AERÉOS LTDA.
lunes, 20 de mayo de 2024

PLAN DE REEMPLAZO DE COMPONENTES AERONAVE

CC-PCS

FOLIO N° 8

T.T. ACTUAL HELICOPT.
804,5 hrs

T.T. ACTUAL MOTOR
804,5 hrs

Item	Descripción	Nro. Parte	REV.	Nro. Serie	Cumple Cada	Cumple Para	INSTALACIÓN / CUMPLIMIENTO			ESTADO ACTUAL			PROXIMO CUMPLMTO.
							F E C H A	TT-ACFT	T. PREVIO	TSO/TSI	DISPONIBLE		
PLAN DE REEMPLAZO DE COMPONENTES													
1	TAIL ROTOR BELLCRANK	A120-3			2200 h	LV	26-mar-2005	0,0 h	0,0 h	804,5 h	1395,5 h	2200,0 h	
					144 m	LV	26-mar-2005	0,0 h	0,0 m	229,9 m	-85 m	-27 d	26-mar-2017
2	SPACER	A130-21			2200 h	LV	N/A por No Inst. (at R44 and R44 Cadet powerplant controls)						
3	SPACER	A130-48			2200 h	LV	26-mar-2005	0,0 h	0,0 h	804,5 h	1395,5 h	2200,0 h	
					144 m	LV	26-mar-2005	0,0 h	0,0 m	229,9 m	-85 m	-27 d	26-mar-2017
4	V-BELT SET	A190-3			2200 h	LV	26-mar-2005	0,0 h	0,0 h	804,5 h	1395,5 h	2200,0 h	
					144 m	LV	26-mar-2005	0,0 h	0,0 m	229,9 m	-85 m	-27 d	26-mar-2017
5	PUSH-PULL TUBE - THROTTLE	A338-6, -9			2200 h	LV	26-mar-2005	0,0 h	0,0 h	804,5 h	1395,5 h	2200,0 h	
6	FITTING	A462-4			2200 h	LV	26-mar-2005	0,0 h	0,0 h	804,5 h	1395,5 h	2200,0 h	
7	CONTROL CABLE - MIXTURE (CARBURETOR)	A522-7			2200 h	LV	N/A por No Inst.						
8	CONTROL CABLE - MIXTURE (FUEL CONTROL)	A522-13			2200 h	LV	26-mar-2005	0,0 h	0,0 h	804,5 h	1395,5 h	2200,0 h	
9	SEAL - VERTICAL FIREWALL (NEOPRENE)	A595-1			2200 h	LV	26-mar-2005	0,0 h	0,0 h	804,5 h	1395,5 h	2200,0 h	
10	SEAL - VERTICAL FIREWALL (TEFLON)	A595-2			2200 h	LV	26-mar-2005	0,0 h	0,0 h	804,5 h	1395,5 h	2200,0 h	
11	TUBE (AUX FUEL PUMP DRAIN)	A729-33			2200 h	LV	26-mar-2005	0,0 h	0,0 h	804,5 h	1395,5 h	2200,0 h	
12	CYCLIC GRIP	A756-8			4400 h	LV	N/A por No Inst.						
13	HOSE (BULKHEAD TO MRGB)	A785-6			2200 h	LV	26-mar-2005	0,0 h	0,0 h	804,5 h	1395,5 h	2200,0 h	
					144 m	LV	26-mar-2005	0,0 h	0,0 m	229,9 m	-85 m	-27 d	26-mar-2017
14	HOSE (ALTERNATOR COOLING)	A785-7			2200 h	LV	26-mar-2005	0,0 h	0,0 h	804,5 h	1395,5 h	2200,0 h	
					144 m	LV	26-mar-2005	0,0 h	0,0 m	229,9 m	-85 m	-27 d	26-mar-2017
15	HOSE (CARB HEAT SCOOP TO AIRBOX)	A785-10			2200 h	LV	N/A por No Inst.						
					144 m	LV	N/A por No Inst.						
16	HOSE (ENGINE LH COWLING TO AIRBOX)	A785-11			2200 h	LV	26-mar-2005	0,0 h	0,0 h	804,5 h	1395,5 h	2200,0 h	
					144 m	LV	26-mar-2005	0,0 h	0,0 m	229,9 m	-85 m	-27 d	26-mar-2017
17	HOSE (SCROLL TO MUFFLER SHROUD)	A785-12			2200 h	LV	26-mar-2005	0,0 h	0,0 h	804,5 h	1395,5 h	2200,0 h	
					144 m	LV	26-mar-2005	0,0 h	0,0 m	229,9 m	-85 m	-27 d	26-mar-2017
18	HOSE (MUFFLER SHROUD TO CABIN HEAT INLET)	A785-13			2200 h	LV	26-mar-2005	0,0 h	0,0 h	804,5 h	1395,5 h	2200,0 h	
					144 m	LV	26-mar-2005	0,0 h	0,0 m	229,9 m	-85 m	-27 d	26-mar-2017
19	HOSE (SCROLL TO MRGB)	A785-16			2200 h	LV	26-mar-2005	0,0 h	0,0 h	804,5 h	1395,5 h	2200,0 h	
					144 m	LV	26-mar-2005	0,0 h	0,0 m	229,9 m	-85 m	-27 d	26-mar-2017



PLAN DE REEMPLAZO DE COMPONENTES AERONAVE
CC-PCS

FOLIO N° 9

T.T. ACTUAL HELICOPT.
804,5 hrs

T.T. ACTUAL MOTOR
804,5 hrs

Marca/Fabricante
ROBINSON HELICOPTER Co.

Modelo
R44 II

N° Serie
10713

Año Fabricación
2005

25 h 2m 50 c

Item	Descripción	Nro. Parte	REV.	Nro. Serie	Cumple Cada	Cumple Para	INSTALACIÓN / CUMPLIMIENTO			ESTADO ACTUAL		PROXIMO CUMPLMTO.
							F E C H A	TT-ACFT	T. PREVIO	TSO/TSI	DISPONIBLE	
20	HOSE (SCROLL TO BULKHEAD)	A785-17			2200 h	LV	26-mar-2005	0,0 h	0,0 h	804,5 h	1395,5 h	2200,0 h
					144 m	LV	26-mar-2005	0,0 h	0,0 m	229,9 m	-85 m	-27 d
21	HOSE (MAGNETO COOLING)	A785-19			2200 h	LV	26-mar-2005	0,0 h	0,0 h	804,5 h	1395,5 h	2200,0 h
					144 m	LV	26-mar-2005	0,0 h	0,0 m	229,9 m	-85 m	-27 d
22	HOSE (BULKHEAD TO HYDRAULIC RESERVOIR)	A785-28			2200 h	LV	26-mar-2005	0,0 h	0,0 h	804,5 h	1395,5 h	2200,0 h
					144 m	LV	26-mar-2005	0,0 h	0,0 m	229,9 m	-85 m	-27 d
23	HOSE (R44 II ENGINE AIR INTAKE)	A785-31			2200 h	LV	26-mar-2005	0,0 h	0,0 h	804,5 h	1395,5 h	2200,0 h
					144 m	LV	26-mar-2005	0,0 h	0,0 m	229,9 m	-85 m	-27 d
24	HOSE (ALTERNATOR COOLING)	A785-32			2200 h	LV	26-mar-2005	0,0 h	0,0 h	804,5 h	1395,5 h	2200,0 h
					144 m	LV	26-mar-2005	0,0 h	0,0 m	229,9 m	-85 m	-27 d
25	ELASTIC CORD – TAIL ROTOR	A918-1 thru -8			2200 h	LV	26-mar-2005	0,0 h	0,0 h	804,5 h	1395,5 h	2200,0 h
					144 m	LV	26-mar-2005	0,0 h	0,0 m	229,9 m	-85 m	-27 d
26	FLEX PLATE ASSEMBLY (BONDED)	A947-2			2200 h	LV	26-mar-2005	0,0 h	0,0 h	804,5 h	1395,5 h	2200,0 h
27	V-BELT – ALTERNATOR	B173-2, -3 or -6			2200 h	LV	26-mar-2005	0,0 h	0,0 h	804,5 h	1395,5 h	2200,0 h
					144 m	LV	26-mar-2005	0,0 h	0,0 m	229,9 m	-85 m	-27 d
28	V-BELT – A/C COMPRESSOR DRIVE	B173-4			2200 h	LV	N/A por No Inst.					
					144 m	LV						
29	CLAMP	B277-024			2200 h	LV	26-mar-2005	0,0 h	0,0 h	804,5 h	1395,5 h	2200,0 h
30	CLAMP	B277-036			2200 h	LV	26-mar-2005	0,0 h	0,0 h	804,5 h	1395,5 h	2200,0 h
31	HOSE ASSEMBLY (OIL PRSSURE SENDER)	B283-1			2200 h	LV	26-mar-2005	0,0 h	0,0 h	804,5 h	1395,5 h	2200,0 h
					144 m	LV	26-mar-2005	0,0 h	0,0 m	229,9 m	-85 m	-27 d
32	HOSE ASSEMBLY (FUEL; VARIOUS)	B283-3			2200 h	LV	26-mar-2005	0,0 h	0,0 h	804,5 h	1395,5 h	2200,0 h
					144 m	LV	26-mar-2005	0,0 h	0,0 m	229,9 m	-85 m	-27 d
33	HOSE ASSEMBLY (FUEL CONTROL TO FLOW DIVIDER)	B283-7			2200 h	LV	26-mar-2005	0,0 h	0,0 h	804,5 h	1395,5 h	2200,0 h
					144 m	LV	26-mar-2005	0,0 h	0,0 m	229,9 m	-85 m	-27 d
34	HOSE ASSEMBLY (FUEL RETURN)	B283-9 or -11			2200 h	LV	26-mar-2005	0,0 h	0,0 h	804,5 h	1395,5 h	2200,0 h
					144 m	LV	26-mar-2005	0,0 h	0,0 m	229,9 m	-85 m	-27 d
35	HOSE ASSEMBLY (ENGINE-DRIVEN PUMP TO FUEL CONTROL)	B283-10			2200 h	LV	26-mar-2005	0,0 h	0,0 h	804,5 h	1395,5 h	2200,0 h
					144 m	LV	26-mar-2005	0,0 h	0,0 m	229,9 m	-85 m	-27 d
36	PITCH LINK (TAIL ROTOR)	B345-4			2200 h	LV	26-mar-2005	0,0 h	0,0 h	804,5 h	1395,5 h	2200,0 h



AGROROTORES
TRABAJOS AEREOS LTDA.
lunes, 20 de mayo de 2024

**PLAN DE REEMPLAZO DE COMPONENTES AERONAVE
CC-PCS**

FOLIO N° 9A

T.T. ACTUAL HELICOPT.
804,5 hrs

T.T. ACTUAL MOTOR
804,5 hrs

Item	Descripción	Nro. Parte	REV.	Nro. Serie	Cumple Cada	Cumple Para	INSTALACIÓN / CUMPLIMIENTO			ESTADO ACTUAL		PROXIMO CUMPLMTO.		
							F E C H A	TT-ACFT	T. PREVIO	TSO/TSI	DISPONIBLE			
37	SPRING PIN (FANWHEEL RETAINING NUT)	B350-3			2200 h	LV	7-ene-2019	699,3 h	0,0 h	105,2 h	2094,8 h	2899,3 h		
38	C154-1 MAIN ROTOR HUB ASSEMBLY	C005-4			2200 h	LV	26-mar-2005	0,0 h	0,0 h	804,5 h	1395,5 h	2200,0 h		
39	C016-7 MAIN ROTOR BLADE & C158-1 SPINDLE ASSY.	C005-12			2200 h	LV	23-ene-2020	736,7 h	0,0 h	67,8 h	2132,2 h	2936,7 h		
					144 m	LV	23-ene-2020	736,7 h	0,0 m	51,9 m	92 m	3 d	23-ene-2032	
40	MAIN ROTOR GEAR BOX ASSY.	C006-5	AA	2582	2200 h	OVH	26-mar-2005	0,0 h	0,0 h	804,5 h	1395,5 h	2200,0 h		
41	FANSHAFT ASSEMBLY	C007-5			2200 h	LV	26-mar-2005	0,0 h	0,0 h	804,5 h	1395,5 h	2200,0 h		
42	TAIL ROTOR ASSEMBLY	C008-4 or -9			2200 h	LV	29-mar-2017	644,3 h	0,0 h	160,2 h	2039,8 h	2844,3 h		
					144 m	LV	29-mar-2017	644,3 h	0,0 m	85,7 m	58 m	8 d	29-mar-2029	
43	MAIN ROTOR BLADE	C016-7	AK	11948	2200 h	LV	23-ene-2020	736,7 h	0,0 h	67,8 h	2132,2 h	2936,7 h		
					144 m	LV	23-ene-2020	736,7 h	0,0 m	51,9 m	92 m	3 d	23-ene-2032	
44	MAIN ROTOR BLADE	C016-7	AK	11954	2200 h	LV	23-ene-2020	736,7 h	0,0 h	67,8 h	2132,2 h	2936,7 h		
					144 m	LV	23-ene-2020	736,7 h	0,0 m	51,9 m	92 m	3 d	23-ene-2032	
45	MAIN ROTOR SWASHPLATE	C017-6	AC	1033	2200 h	OVH	11-feb-2020	736,7 h	0,0 h	67,8 h	2132,2 h	2936,7 h		
46	CLUTCH ASSEMBLY (C186-4 SHAFT)	C018-2 or -3			2200 h	LV	26-mar-2005	0,0 h	0,0 h	804,5 h	1395,5 h	2200,0 h		
					144 m	LV	26-mar-2005	0,0 h	0,0 m	229,9 m	-85 m	-27 d	26-mar-2017	*
47	CLUTCH ASSEMBLY (C186-5 SHAFT)	C018-4 or -5			2200 h	LV	N/A por No Inst.							
48	UPPER FRAME ASSEMBLY (STANDARD)	C020-1	U	2455	2200 h	LV	26-mar-2005	0,0 h	0,0 h	804,5 h	1395,5 h	2200,0 h		
49	TAIL ROTOR GEAR BOX ASSY.	C021-1	J	2359	2200 h	OVH	26-mar-2005	0,0 h	0,0 h	804,5 h	1395,5 h	2200,0 h		
50	TAIL CONE ASSY	C023-1	AH	2422	4400 h	LV	26-mar-2005	0,0 h	0,0 h	804,5 h	3595,5 h	4400,0 h		
51	TAIL CONE ASSY	C023-2, -3, -4, -14, & -15			4400 h	LV	N/A por No Inst.							
52	TAIL ROTOR BLADE	C029-3	O	6557	2200 h	LV	29-mar-2017	644,3 h	0,0 h	160,2 h	2039,8 h	2844,3 h		
					144 m	LV	29-mar-2017	644,3 h	0,0 m	85,7 m	58 m	8 d	29-mar-2029	
53	TAIL ROTOR BLADE	C029-3	O	6629	2200 h	LV	29-mar-2017	644,3 h	0,0 h	160,2 h	2039,8 h	2844,3 h		
					144 m	LV	29-mar-2017	644,3 h	0,0 m	85,7 m	58 m	8 d	29-mar-2029	
54	TAIL ROTOR HUB	C030-1			2200 h	LV	N/A por No Inst.							
55	TAIL ROTOR PITCH CONTROL	C031-1	J	2634	2200 h	LV	26-mar-2005	0,0 h	0,0 h	804,5 h	1395,5 h	2200,0 h		
					144 m	LV	26-mar-2005	0,0 h	0,0 m	229,9 m	-85 m	-27 d	26-mar-2017	*
56	BEARING ASSEMBLY - TRDS DAMPER	C041-11			144 m	LV	26-mar-2005	0,0 h	0,0 m	229,9 m	-85 m	-27 d	26-mar-2017	*
57	HORIZONTAL STABILIZER	C044-1	Q	2462	4400 h	LV	26-mar-2005	0,0 h	0,0 h	804,5 h	3595,5 h	4400,0 h		
58	CLUTCH ACTUATOR ASSEMBLY	C051-2	T	2495	2200 h	OVH	26-mar-2005	0,0 h	0,0 h	804,5 h	1395,5 h	2200,0 h		



AGROROTORES
TRABAJOS AEREOS LTDA.
Lunes, 20 de mayo de 2024

PLAN DE REEMPLAZO DE COMPONENTES AERONAVE
CC-PCS

FOLIO N° 9B

T.T. ACTUAL HELICOPT.
804,5 hrs

T.T. ACTUAL MOTOR
804,5 hrs

Marca/Fabricante
ROBINSON HELICOPTER Co.

Modelo
R44 II

N°/Serie
10713

Año Fabricación
2005

Criterios para advertencia

25 h 2m 50 c

Item	Descripción	Nro. Parte	REV.	Nro. Serie	Cumple Cada	Cumple Para	INSTALACIÓN / CUMPLIMIENTO			ESTADO ACTUAL		PROXIMO CUMPLMTO.
							FECHA	TT-ACFT	T. PREVIO	TSO/TSI	DISPONIBLE	
59	BUMPER – TAIL ROTOR	C119-2			2200 h	LV	26-mar-2005	0,0 h	0,0 h	804,5 h	1395,5 h	2200,0 h
					144 m	LV	26-mar-2005	0,0 h	0,0 m	229,9 m	-85 m	-27 d
60	PUSH-PULL TUBE (TAILCONE)	C121-17			2200 h	LV	26-mar-2005	0,0 h	0,0 h	804,5 h	1395,5 h	2200,0 h
61	LYCOMING ENG. IO-540-AE1A5	C145-2	T	L-30092-48A	2200 h	OVH	16-mar-2005	0,0 h	0,0 h	804,5 h	1395,5 h	2200,0 h
					144 m	OVH	16-mar-2005	0,0 h	0,0 m	230,2 m	-86 m	-7 d
62	PINION, MAIN GEARBOX	C146-2			2200 h	LV	N/A por No Inst.					
63	MAIN ROTOR GEAR SET	C146-5	K	2878	2200 h	LV	26-mar-2005	0,0 h	0,0 h	804,5 h	1395,5 h	2200,0 h
64	MAIN ROTOR HUB	C154-1	E	2518	2200 h	LV	26-mar-2005	0,0 h	0,0 h	804,5 h	1395,5 h	2200,0 h
65	MAIN ROTOR SPINDLE	C158-1	M	25670	2200 h	LV	23-ene-2020	736,7 h	0,0 h	67,8 h	2132,2 h	2936,7 h
66	MAIN ROTOR SPINDLE	C158-1	M	25671	2200 h	LV	23-ene-2020	736,7 h	0,0 h	67,8 h	2132,2 h	2936,7 h
67	SHAFT-CLUTCH (C018)	C166-4	N	3081	2200 h	OVH	26-mar-2005	0,0 h	0,0 h	804,5 h	1395,5 h	2200,0 h
68	EXHAUST MUFFLER ASSEMBLY	C169-1 or -35			2200 h	LV	N/A por No Inst.					
69	EXHAUST MUFFLER ASSEMBLY	C169-31 or -37			2200 h	LV	26-mar-2005	0,0 h	0,0 h	804,5 h	1395,5 h	2200,0 h
70	BEARING ASSY/LOWER SHEAVE	C181-3	H	2802	2200 h	OVH	26-mar-2005	0,0 h	0,0 h	804,5 h	1395,5 h	2200,0 h
71	NUT (FANWHEEL RETAINING)	C182-1			2200 h	LV	26-mar-2005	0,0 h	0,0 h	804,5 h	1395,5 h	2200,0 h
72	SPRAG CLUTCH	C188-3	G	3951	2200 h	OVH	26-mar-2005	0,0 h	0,0 h	804,5 h	1395,5 h	2200,0 h
73	NUT (MR HUB BOLT)	C189-14			2200 h	LV	23-ene-2020	736,7 h	0,0 h	67,8 h	2132,2 h	2936,7 h
74	TAIL ROTOR DRIVE SHAFT	C196-1			2200 h	LV	N/A por No Inst.					
75	LOWER SWASHPLATE	C198-1 & -2			4400 h	LV	N/A por No Inst.					
76	MAIN ROTOR DRIVE SHAFT	C251-1			4400 h	OVH	N/A por No Inst.					
77	MAIN ROTOR DRIVE SHAFT	C251-2	M	R3408	2200 h	OVH	26-mar-2005	0,0 h	0,0 h	804,5 h	1395,5 h	2200,0 h
78	MAIN ROTOR GEARBOX SUMP	C263-2	G	0068	2200 h	LV	26-mar-2005	0,0 h	0,0 h	804,5 h	1395,5 h	2200,0 h
79	MAIN ROTOR GEARBOX HOUSING	C264-1	I	2582	2200 h	LV	26-mar-2005	0,0 h	0,0 h	804,5 h	1395,5 h	2200,0 h
80	CYCLIC TORQUE TUBE	C319-3			4400 h	LV	N/A por No Inst.					
81	CYCLIC STICK	C320-1			4400 h	LV	N/A por No Inst.					
82	JACKSHAFT	C337-1			4400 h	LV	N/A por No Inst.					
83	SWASHPLATE BOOT	C480-1			2200 h	LV	26-mar-2005	0,0 h	0,0 h	804,5 h	1395,5 h	2200,0 h
					144 m	LV	26-mar-2005	0,0 h	0,0 m	229,9 m	-85 m	-27 d
84	CONTROL CABLE – CARBURETOR HEAT	C522-7			2200 h	LV	N/A por No Inst.					
85	GEAR SET, TAIL GEARBOX	C545-1	H	2834	2200 h	LV	26-mar-2005	0,0 h	0,0 h	804,5 h	1395,5 h	2200,0 h



AGROROTORES
TRABAJOS AEREOS LTDA.
Lunes, 20 de mayo de 2024

**PLAN DE REEMPLAZO DE COMPONENTES AERONAVE
CC-PCS**

FOLIO N° 9C

T.T. ACTUAL HELICOPT.
804,5 hrs

T.T. ACTUAL MOTOR
804,5 hrs

Marca/Fabricante: ROBINSON HELICOPTER Co. Modelo: R44 II N° Serie: 10713 Año Fabricación: 2005 Criterios para advertencia: 25 h, 2m, 50 c

Item	Descripción	Nro. Parte	REV.	Nro. Serie	Cumple Cada	Cumple Para	INSTALACIÓN / CUMPLIMIENTO			ESTADO ACTUAL		PROXIMO	
							F E C H A	TT-ACFT	T. PREVIO	TSO/TSI	DISPONIBLE	CUMPLMTO.	
86	TAIL ROTOR GEAR SET	C545-2			2200 h	LV				N/A por No Inst.			
87	SCOOP ASSEMBLY (CARBURETOR HEAT)	C568-1			2200 h	LV				N/A por No Inst.			
88	GASKET (AIRBOX-TO-CARBURETOR)	C815-1			2200 h	LV				N/A por No Inst.			
89	4-5-POINT HARNESS ASSEMBLY	C827-4, -5, or -8			2200 h	LV	26-mar-2005	0,0 h	0,0 h	804,5 h	1395,5 h	2200,0 h	
90	CONNECTOR ASSEMBLY	C828-5, -6, -7, or -8			2200 h	LV	26-mar-2005	0,0 h	0,0 h	804,5 h	1395,5 h	2200,0 h	
91	BEARING SET SWASHPLATE	C847-12	AC	A192591	2200 h	LV	11-feb-2020	736,7 h	0,0 h	67,9 h	2132,2 h	2936,7 h	
92	NOZZLE ASSEMBLY (MRGB COOLING)	C749-1			2200 h	LV	26-mar-2005	0,0 h	0,0 h	804,5 h	1395,5 h	2200,0 h	
93	DUAL TACHOMETER	C792-4		2264	2200 h	OVH	26-mar-2005	0,0 h	0,0 h	804,5 h	1395,5 h	2200,0 h	
94	FLEX PLATE ASSEMBLY (FORWARD & AFT)	C847-1 & -3			2200 h	LV	26-mar-2005	0,0 h	0,0 h	804,5 h	1395,5 h	2200,0 h	
95	TAIL ROTOR HUB	D082-2			2200 h	LV				N/A por No Inst.			
96	MAIN TANK BLADDER	D028-1			2200 h	OVH				N/A por No Inst.			
97	AUX TANK BLADDER	D028-2			2200 h	OVH				N/A por No Inst.			
98	TAIL ROTOR GUARD	D079-1	V	7126	2200 h	LV	10-mar-2012	396,5 h	0,0 h	408,0 h	1792,0 h	2596,5 h	
99	STOP (TEETER, 2 EACH)	D151-2			144 m	LV	23-ene-2020	736,7 h	0,0 m	51,9 m	92 m	3 d	23-ene-2032
100	FANWHEEL	D174-2			2200 h	OVH	26-mar-2005	0,0 h	0,0 h	804,5 h	1395,5 h	2200,0 h	
101	TAIL ROTOR DRIVE SHAFT	D196-1	B	0559	4400 h	LV	26-mar-2005	0,0 h	0,0 h	804,5 h	3595,5 h	4400,0 h	
102	SUPPORT ASSEMBLY - HYDRAULIC SERVOS (FWD)	D201-5			2200 h	LV	26-mar-2005	0,0 h	0,0 h	804,5 h	1395,5 h	2200,0 h	
					144 m	LV	26-mar-2005	0,0 h	0,0 m	229,9 m	-85 m	-27 d	26-mar-2017
103	HYDRAULIC RESERVOIR	D211-2	H	1594	2200 h	OVH	26-mar-2005	0,0 h	0,0 h	804,5 h	1395,5 h	2200,0 h	
104	HYDRAULIC SERVO	D212-1	G	4714	2200 h	OVH	26-mar-2005	0,0 h	0,0 h	804,5 h	1395,5 h	2200,0 h	
105	HYDRAULIC SERVO	D212-1	G	4715	2200 h	OVH	26-mar-2005	0,0 h	0,0 h	804,5 h	1395,5 h	2200,0 h	
106	HYDRAULIC SERVO	D212-1	M	19333	2200 h	OVH	15-jun-2022	785,9 h	0,0 h	38,6 h	2161,4 h	2965,9 h	
107	TAIL ROTOR DRIVE SHAFT ASSEMBLY	D224-1			2200 h	LV	26-mar-2005	0,0 h	0,0 h	804,5 h	1395,5 h	2200,0 h	
108	GOVERNOR CONTROLLER (WITH EMU)	D270-1			2200 h	OVH				N/A por No Inst.			
109	GOVERNOR CONTROLLER	D278-2	E	0761	2200 h	OVH	26-mar-2005	0,0 h	0,0 h	804,5 h	1395,5 h	2200,0 h	
110	VALVE - PRESSURE RELIEF (FUEL)	D321-1			2200 h	OVH	26-mar-2005	0,0 h	0,0 h	804,5 h	1395,5 h	2200,0 h	
					144 m	OVH	26-mar-2005	0,0 h	0,0 m	229,9 m	-85 m	-27 d	26-mar-2017
111	FITTING (CARB HEAT CONTROL CABLE)	D333-3			2200 h	LV				N/A por No Inst.			
112	HYDRAULIC PUMP ASSY	D500-1	F	1685	2200 h	OVH	26-mar-2005	0,0 h	0,0 h	804,5 h	1395,5 h	2200,0 h	
113	SPACER (FUEL CONTROL THROTTLE BELLOWANK)	D543-2			2200 h	OVH	26-mar-2005	0,0 h	0,0 h	804,5 h	1395,5 h	2200,0 h	



**PLAN DE REEMPLAZO DE COMPONENTES AERONAVE
CC-PCS**

FOLIO N° 9D

T.T. ACTUAL HELICOPT.
804,5 hrs

T.T. ACTUAL MOTOR
804,5 hrs

Marca/Fabricante
ROBINSON HELICOPTER Co.

Modelo
R44 II

N°/Serie
10713

Año Fabricación
2005

Criterios para advertencia
25 h 2m 50 c

Item	Descripción	Nro. Parte	REV.	Nro. Serie	Cumple Cada	Cumple Para	INSTALACIÓN / CUMPLIMIENTO			ESTADO ACTUAL		PROXIMO CUMPLMTO.	
							F E C H A	TT-ACFT	T. PREVIO	TSO/TSI	DISPONIBLE		
114	BRACE (FUEL CONTROL)	D730-8			2200 h	OVH	26-mar-2005	0,0 h	0,0 h	804,5 h	1395,5 h	2200,0 h	
115	SLEEVE - FUEL CONTROL INLET FITTING (ORANGE INSULATED)	D735-1			2200 h	OVH	26-mar-2005	0,0 h	0,0 h	804,5 h	1395,5 h	2200,0 h	
116	PUMP - FUEL (ELECTRIC)	D743-1, -2, -3 or -4			2200 h	OVH	26-mar-2005	0,0 h	0,0 h	804,5 h	1395,5 h	2200,0 h	
117	CARTRIDGE - AIR CONDITIONING PULLEY DRIVE (R44 II or Cadet only)	D778-1			2200 h	LV	N/A por No Inst.						
					144 m	LV							
118	ELASTIC CORDS - CYCLIC	D918-1 & -2			2200 h	LV	26-mar-2005	0,0 h	0,0 h	804,5 h	1395,5 h	2200,0 h	
					144 m	LV	26-mar-2005	0,0 h	0,0 m	229,9 m	-85 m	-27 d	26-mar-2017
119	MIXTURE SPRING (FUEL CONTROL)	D930-1			2200 h	LV	26-mar-2005	0,0 h	0,0 h	804,5 h	1395,5 h	2200,0 h	
120	CONNECTOR ASSEMBLY	F628-1			2200 h	LV	26-mar-2005	0,0 h	0,0 h	804,5 h	1395,5 h	2200,0 h	
121	CONNECTOR ASSEMBLY	F628-3			2200 h	LV	26-mar-2005	0,0 h	0,0 h	804,5 h	1395,5 h	2200,0 h	
122	BUCKLE ASSEMBLY	F628-7			2200 h	LV	26-mar-2005	0,0 h	0,0 h	804,5 h	1395,5 h	2200,0 h	
123	TAIL ROTOR HUB ASSY	G062-2	E	4150	2200 h	LV	29-mar-2017	644,3 h	0,0 h	160,2 h	2039,8 h	2844,3 h	
124	BOLT (OIL COOLER RETAINING)	AN3-41A			2200 h	LV	26-mar-2005	0,0 h	0,0 h	804,5 h	1395,5 h	2200,0 h	
125	BOLT (OIL COOLER RETAINING)	AN3-44A			2200 h	LV	26-mar-2005	0,0 h	0,0 h	804,5 h	1395,5 h	2200,0 h	
126	CLAMP (MIXTURE CABLE-TO-CS77-2 BRACKET)	AN735-4			2200 h	LV	26-mar-2005	0,0 h	0,0 h	804,5 h	1395,5 h	2200,0 h	
127	SPRING PIN (IN D333-3 FITTING)	MS16562-4			2200 h	LV	N/A por No Inst.						
128	WASHER (THICK, FANWHEEL RETAINING NUT)	MS20002-24			2200 h	LV	26-mar-2005	0,0 h	0,0 h	804,5 h	1395,5 h	2200,0 h	
129	WASHER (CORROSION RESISTANT, MIXTURE ARM, 2 EACH)	NAS1149E0363R			2200 h	LV	26-mar-2005	0,0 h	0,0 h	804,5 h	1395,5 h	2200,0 h	
					144 m	LV	26-mar-2005	0,0 h	0,0 m	229,9 m	-85 m	-27 d	26-mar-2017
130	WASHER (THIN, FANWHEEL RETAINING NUT)	NAS1149F2432P			2200 h	LV	26-mar-2005	0,0 h	0,0 h	804,5 h	1395,5 h	2200,0 h	
131	BOLT (MR HUB)	NAS634-105			2200 h	LV	23-ene-2020	736,7 h	0,0 h	67,8 h	2132,2 h	2936,7 h	
132	NUT (EXHAUST RISER, 12 EACH)	21FKF-518			2200 h	LV	26-mar-2005	0,0 h	0,0 h	804,5 h	1395,5 h	2200,0 h	
					144 m	LV	26-mar-2005	0,0 h	0,0 m	229,9 m	-85 m	-27 d	26-mar-2017
133	JAM NUT (MR PITCH LINK, 2 EACH)	21FKF-813			144 m	LV	26-mar-2005	0,0 h	0,0 m	229,9 m	-85 m	-27 d	26-mar-2017
134	ELT BATTERY (ARTEX ME 406HM)	455-0012		391369-026	84 m	LV	30-may-2021	750,1 h	0,0 m	35,7 m	51 m	12 d	31-ago-2028

* No se realiza inspección porque se acoje a DAN 92 Vol. III.

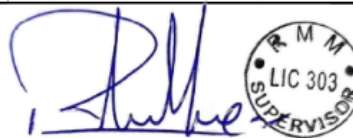

Plan de Reemplazo Componentes Motor



AGROROTORES
TRABAJOS AÉREOS LTDA.
Lunes, 20 de mayo de 2024

PLAN DE REEMPLAZO DE COMPONENTES MOTOR CC-PCS

FOLIO N° 7

T.T. ACTUAL HELICOPT.
804,5 hrs

T.T. ACTUAL MOTOR
804,5 hrs

Item	Descripción	Nro. Parte	REV.	Nro. Serie	Cumple Cada	Cumple Para	INSTALACIÓN / CUMPLIMIENTO			ESTADO ACTUAL			PROXIMO CUMPLMTO.
							FECHA	TT-ACFT	T. PREVIO	TSO/TSI	DISPONIBLE	25 h	
1	ACEITE MOTOR	Perform Lyc. SB 480F: Oil and Filter Change and Screen Cleaning; Oil Filter/Screen Content Inspection.			50 h	LV	20-may-2024	804,5 h	0,0 h	0,0 h	50,0 h	854,5 h	
					4 m	LV	20-may-2024	804,5 h	0,0 m	0,0 m	4 m	12 d	30-sept-2024
2	LYCOMING ENG. IO-540-AE1A5	C145-2	T	L-30092-48A	2200 h	OVH	16-mar-2005	0,0 h	0,0 h	804,5 h	1395,5 h	2200,0 h	
					144 m	OVH	16-mar-2005	0,0 h	0,0 m	230,2 m	-85 m	-20 d	mar-2017
3	OIL COOLER (Stewart Warner)	10886A		1987	2200 h	OVH	16-mar-2005	0,0 h	0,0 h	804,5 h	1395,5 h	2200,0 h	
					144 m	OVH	16-mar-2005	0,0 h	0,0 m	230,2 m	-85 m	-20 d	mar-2017
4	OIL COOLER, SMALL (Stewart Warner)	10599R		4938	2200 h	OVH	16-mar-2005	0,0 h	0,0 h	804,5 h	1395,5 h	2200,0 h	
					144 m	OVH	16-mar-2005	0,0 h	0,0 m	230,2 m	-85 m	-20 d	mar-2017
5	MAGNETO , LEFT (S6LSC-200)	10-800616-9		E04IA083	2200 h	OVH	17-may-2023	792,1 h	0,0 h	12,4 h	2187,6 h	2992,1 h	
					500 h	IN	17-may-2023	792,1 h	0,0 h	12,4 h	487,6 h	1292,1 h	
					48 m	OVH	17-may-2023	792,1 h	0,0 m	12,1 m	36 m	11 d	may-2027
6	MAGNETO, RIGHT (S6LSC-204T)	10-800646-201		E04IA314	2200 h	OVH	17-may-2023	792,1 h	0,0 h	12,4 h	2187,6 h	2992,1 h	
					500 h	IN	17-may-2023	792,1 h	0,0 h	12,4 h	487,6 h	1292,1 h	
					48 m	OVH	17-may-2023	792,1 h	0,0 m	12,1 m	36 m	11 d	may-2027
7	ALTERNATOR (Kelly Aerospace)	ALU-8521LS		F014299	2200 h	OVH	16-mar-2005	0,0 h	0,0 h	804,5 h	1395,5 h	2200,0 h	
					144 m	OVH	16-mar-2005	0,0 h	0,0 m	230,2 m	-85 m	-20 d	mar-2017
8	FUEL CONTROL SERVO (Presicion Air.)	RSA-10AD1		70761606	2200 h	OVH	16-mar-2005	0,0 h	0,0 h	804,5 h	1395,5 h	2200,0 h	
					144 m	OVH	16-mar-2005	0,0 h	0,0 m	230,2 m	-85 m	-20 d	31-mar-2017
9	STARTER (B&C Specialty Product)	BC315-100-4		0604240638	2200 h	OVH	15-mar-2007	193,3 h	0,0 h	611,2 h	1588,8 h	2393,3 h	

* No se realiza inspección porque se acoje a DAN 92 Vol. III.

Esperando haber brindado una respuesta satisfactoria a su consulta, reiteramos nuestro compromiso con la excelencia en el servicio y la satisfacción de nuestros clientes. Estamos a su disposición para cualquier información adicional que pueda necesitar y le agradecemos por su confianza en nosotros.

¡Que tenga un excelente día!



Hansell Martinez | Ejecutivo Comercial

Aeródromo de Chicureo, Camino Guay Guay 8881 Colina, CHILE.

T: +562 29483200 | C: +569 672 66753

hmartinez@eaglecopters.cl | <http://www.eaglecopters.cl/>

REPRESENTANTE DE VENTAS



PARTES Y REPUESTOS



