



Datasheet of

# **BELL 407 GXi**

S/N 54832





# COTIZACIÓN BELL 407 GXi S/N 54832

**Matricula:** CC-DBG

**T.T. Actual Helicóptero:** 1300.1 Horas

**Año de Fabricación:** 2019

**T.S.N. Actual Motor:** 1208.8 Horas

En atención a la solicitud de cotización para el helicóptero marca Bell, modelo 407 GXi, matrícula CC-DBG, tenemos el agrado de cotizar conforme al siguiente detalle:

## I. Dimensiones y Especificaciones Técnicas

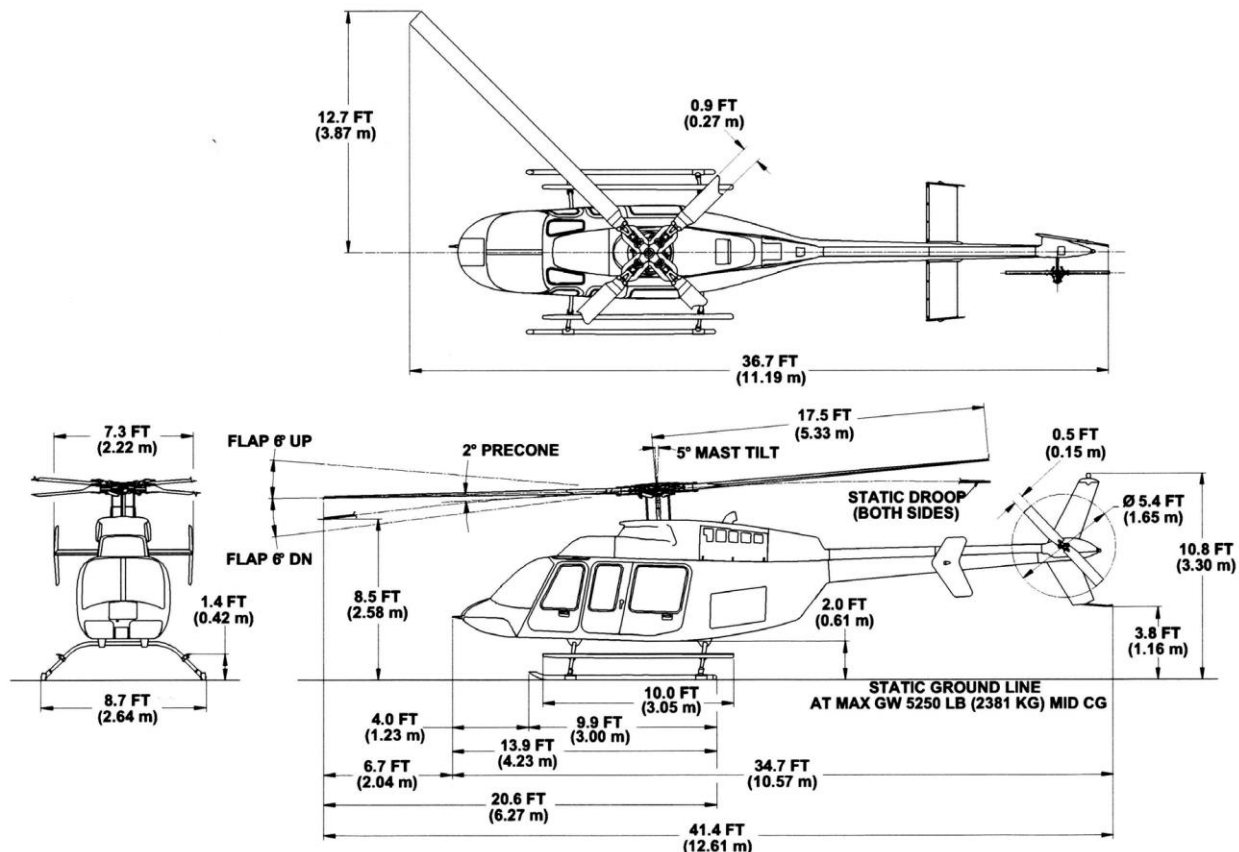

### Especificaciones Técnicas Bell 407 GXi

Engine	Rolls-Royce 250-C47E/4 with Full Authority Digital Electronic Control
Horsepower	Derated to 674 SHP for takeoff and 639 SHP continuous
Maximum Internal Gross Weight (Normal/ Optional)	5,000 / 5,250 lb (2268 kg/ 2381 kg)
Approximate Empty Weight (including oil & standard avionics)	2,700 lb (1225 kg)
Useful Load (Base Aircraft, Normal / Optional)	2,300 lb / 2,550 lb
Max Gross Weight with External Load	6,000 lb (2722 kg)
Max External Load (Cargo Hook Limit)	3,100 lb (1406 kg)
Standard Fuel	127.8 gal
Auxiliary Fuel	19.0 gal
Cruise Speed at Maximum Gross Weight	up to 120 kts
Maximum Range (no reserve)	approx 332 nm (615 km)
Hover Ceiling IGE	19000 ft @ 4000 lb
Hover Ceiling OGE	18720 ft @ 4000 lb

## II. Configuración del Helicóptero



Configuración del Helicóptero	
Configuración	Corporativo
Tripulación/ Pasajeros	1 Piloto/ 6 Pasajeros
Equipos Instalados	
Standby Compass	
Standby Indicator MD302	
Display Unit GDU 1050H (PFD)	
Display Unit GDU 1050H (MFD)	
Engine Signal Processor GEA 71BH	
ADC/AHRS GSU 75H	
Oat probe GTP 59	
Magnetometer MGU-44	
VHF #1 Radio GIA 64H	
Com Antenna #1	
GPS Antenna	
Diplexer	
VHF #2 Radio GIA 64H	
Com/GPS Antenna #2	
Audio Panel Pilot GMA 350Hc	
Transponder GTX-335R	
Transponder Antenna KA61	
ELT C406-NHM	
E.L.T. Antenna	
Remote ELT Switch	
ELT Buzzer	
ELT Programming Adapter	
Aft Avionic Shelf	
Radar Altimeter Transceiver GRA55	
Radar Alt Antenna TX	
Radar Alt Antenna RX	
TAS Processor GTS 800	
TAS Antenna	

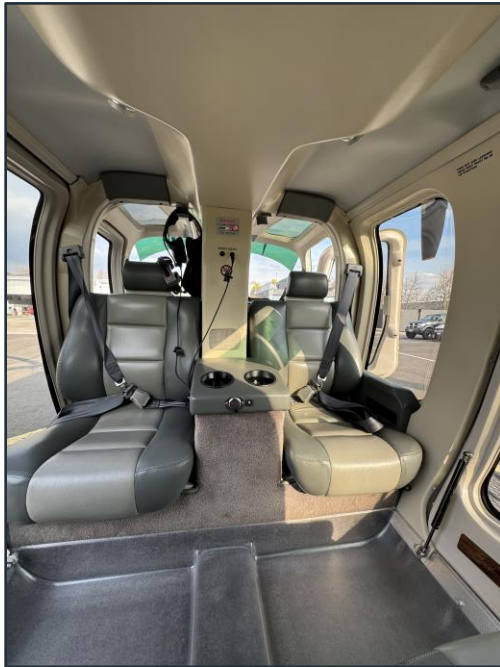

Tailboom Antenna Mount
Starter / Generator
Pilot Restraint
Forward Passenger Restraint
Mid Passenger LH Restraint
Mid Passenger RH Restraint
Alt Passenger LH Restraint
Alt Passenger Centre Restraint
Alt Passenger RH Restraint
Crew Floor Protector
Passenger Floor Protector
Baggage Floor Protector
Crew Assist Handle
Locking Fuel Cap
Fwd Cross-Tube
Aft Cross-Tube
Skid Tube L/H
Skid Tube R/H
FliteSteps L/H
FliteSteps R/H
Anti-Collision Light
Landing/ Taxi Light (2)
Green Position Light RH (Fuselage)
Red Position Light LH (Fuselage)
Green Position Light RH (Aux Fin)
Red Position Light LH (Aux Fin)
Tail Light
Map (Utility) Light
Nightscanner
Fire Extinguisher, Hand Type
Collective Stick Assy (CoPilot)
Cyclic Stick Assy (CoPilot)



Aft Avionic Shelf
Tail Rotor Camera
ELT Prov
Autopilot
Autopilot Controller
AFCS Retrofit
28 AmpH Battery
Interior - Corporate
Soundproofing - Corporate
Armrests - Corporate
Seats - Corporate Leather
Headliner with ECS Ducts
Aux Tank Equipment
Aux Tank Provisions
High Skid Gear
Rotor Brake
Dual Controls
Cargo Hook Provisions Bell
Sliding Windows
WSPS (High Skid Gear)
WSPS Provisions
Inlet Barrier Filter
Door Opener, Baggage
Cargo Mirror
FliteSteps
Standby Attitude MO302
Floor Protector Kit
Spacemaker
Door Opener, Cabin
Folding Maintenance Step
Pre-flight Step/Handle Kit
Door Opener, High Visibility
High Visibility Crew Door Kit
High Visibility Cabin Door Kit
Dual Evaporator Air Conditioning



Heater, Dual Outlet
Engine Compartment Bleed Air
Chin Bubble Defog
Radar Altimeter GRASS
Cockpit/Cabin Call Circuit
Re-Wire Crew Headset Jacks
ICS - 7 Place w Bose LEMO Jacks
Baggage Edge Protector
Leather Center Map & Flight Manual Pockets
Fire Extinguisher, Hand Type
Flight Manual
First Aid Kit
Collective Stick Assy (CoPilot)
Cyclic Stick Assy (CoPilot)
Heli Utility Basket
Quick Release Heli Access Step RH
Bearpaws
Quick Release Basket Mounting

### **III. Precio y Forma de Pago**

El asking price del helicóptero es de US \$4,100,000.00 + IVA.

**Forma de Pago:** Posterior a la ejecución y firma de la LOI, el oferente/comprador tiene 05 día hábiles para realizar el depósito reembolsable correspondiente a un 4% del valor de compra de la aeronave en la cuenta de Eagle Copters S.A., a título de reserva y constituirá un anticipo del precio de venta acordado, en caso de efectuarse la compraventa, de no llegar a acuerdo el depósito se reembolsará.

La diferencia entre el precio de compra pactado y el depósito de reserva, impuestos aplicables incluidos, será pagadero, salvo que se pacte algo diferente, mediante depósito a plazo en USD endosable, el que quedará en notaría con instrucciones de entregarlo al vendedor una vez que la aeronave haya quedado debidamente inscrita a nombre del oferente/comprador en el respectivo registro del conservador de aeronaves de la DGAC.

### **IV. Plazo de Entrega**

Una vez ejecutados y firmados los respectivos acuerdos, contratos e inscripciones a nombre del nuevo propietario de la aeronave, esta será entregada de forma **inmediata**.

### **V. Fotos**







Esperando haber brindado una respuesta satisfactoria a su consulta, reiteramos nuestro compromiso con la excelencia en el servicio y la satisfacción de nuestros clientes. Estamos a su disposición para cualquier información adicional que pueda necesitar y le agradecemos por su confianza en nosotros.

¡Que tenga un excelente día!



**Hansell Martinez | Ejecutivo Comercial**

Aeródromo de Chicureo, Camino Guay Guay 8881 Colina, CHILE.

T: +562 29483200 | C: +569 67266753

[hmartinez@eaglecopters.cl](mailto:hmartinez@eaglecopters.cl) | <http://www.eaglecopters.cl/>

REPRESENTANTE DE VENTAS



PARTES Y REPUESTOS



